

Super Collet Style Tube Puller



Tube & Pipe Cleaners ◦ Tube Testers ◦ Tube Plugs ◦ Tube Removal ◦ Tube Installation



Operating and Maintenance Instructions

TABLE OF CONTENTS

Introduction 5

Safety Guidelines 6

Assembly Instructions 9

Parts List & Diagrams 10

Start-up 11

Tool Changeover 12

Operation..... 14

Troubleshooting 15

Warranty 16

This page intentionally left blank.

INTRODUCTION

Thank you for purchasing this Elliott product. More than 100 years of experience have been employed in the design and manufacture of this product, representing the highest standard of quality, value and durability. Elliott tools have proven themselves in thousands of hours of trouble-free field operation.

If this is your first Elliott purchase, welcome to our company; our products are our ambassadors. If this is a repeat purchase, you can rest assured that the same value you have received in the past will continue with all of your purchases, now and in the future.

If you have any questions regarding this product, manual or operating instructions, please call Elliott at +1 800 332 0447 toll free (USA only) or +1 937 253 6133, or fax us at +1 937 253 9189 for immediate service.

SAFETY GUIDELINES

Read and save all instructions. Before use, be sure everyone using this machine reads and understands this manual, as well as any labels packaged with or attached to the machine.

DANGER

Under **no circumstances** should **anyone** be at the opposite end of the tube during operation. Potential for projectile that can result in serious injury or fatality. The Deflector Shield should be used at all times.

WARNING

When using electric tools, certain safety precautions are required to reduce the risk of electrical shock and personal injury.

WARNING

To reduce the risk of injury, always unplug your machine before performing any maintenance. Never disassemble the machine or try to do any wiring on the electrical system. Contact Elliott for all repairs.

- Know Your Elliott Tool. Read this manual carefully to learn your tool's application and limitations as well as the potential hazards specific to this tool.
- Ground Your Elliott Tool. Always use properly grounded electrical outlets, and if using an extension cord, make sure that it is of the proper size for the electrical load and it is equipped with a ground wire and ground plug.
- Avoid Dangerous Environments. Do not use power tools in damp or wet locations
- Keep Work Area Clean and Well Lit. Cluttered, dark work areas invite accidents.
- Dress Properly. Do not wear loose clothing or jewelry. Wear a protective hair covering to contain long hair. It is recommended that the operator wear safety glasses with side shields or a full face shield eye protection.
- Use Safety Equipment. Everyone in the work area should wear safety goggles or glasses with side shields complying with current safety standards. Wear hearing protection during extended use, respirator for a confined space and a dust mask for dusty operations. Hard hats, face shields, safety shoes, respirators, etc. should be used when specified or necessary. Keep a fire extinguisher nearby.

SAFETY GUIDELINES

- Always disconnect the tool from the power source before making any adjustments to tool accessories connected to the tool.
- Operators and maintenance personnel must be physically able to handle the bulk, weight, and power of the tool.
- Keep Bystanders Away. Bystanders should be kept at a safe distance from the work area to avoid distracting the operator.
- Use The Right Tools. Do not force a tool or attachment to do a job or operate at a speed it was not designed for.
- Use Proper Accessories. Use Elliott accessories only. Be sure accessories are properly installed and maintained.
- Check for Damaged Parts. Inspect guards and other parts before use. Check for misalignment, binding of moving parts, improper mounting, broken parts or any other conditions that may affect operation. If abnormal noise or vibration occurs, turn the tool off immediately and have the problem corrected before further use. Do not use a damaged tool. Tag damaged tools “Do Not Use” until repaired. A damaged part should be properly repaired or replaced by an Elliott service facility. For all repairs, insist on only identical replacement parts.
- Keep Hands Away from All Moving Parts. Do Not Overreach. Maintain Control. Keep proper footing and balance at all times.
- Stay Alert. DO NOT use a tool when you are tired, distracted or under the influence of drugs, alcohol or any medication causing decreased control.
- Maintain Labels and Nameplates. These carry important information and will assist you in ordering spare and replacement parts. If unreadable or missing, contact an Elliott service facility for a replacement.
- DO NOT attempt to adjust or service the rod end relief valve on a double-acting cylinder or ram. If oil leakage is detected from this relief valve, discontinue use of the cylinder or ram immediately and contact your nearest Authorized Hydraulic Service Center. If improperly adjusted, the cylinder or ram could develop excessive pressure and cause the cylinder, hose or couplers to burst which could cause serious injury or death.
- When extending a cylinder or ram under load, always ensure that the coupler(s) or port thread(s) has (have) not been damaged or do(es) not come in contact with any rigid obstruction. If this condition does occur, the coupler’s attaching threads may become stripped or pulled from the cylinder or ram resulting in the instantaneous release of high pressure hydraulic fluid, flying objects, and loss of the load. All of these possible results could cause serious injury or death.
- Should a hydraulic hose ever rupture, burst, or need to be disconnected, immediately shut off the pump and release all pressure. Never attempt to grasp a leaking pressurized hose with your hands. The force of escaping hydraulic fluid could cause serious injury.
- Do not subject the hose to potential hazard such as fire, sharp surfaces, extreme heat or cold, or heavy impact. Do not allow the hose to kink, twist, curl, crush, cut, or bend so tightly that the fluid flow within the hose is blocked or reduced. Periodically inspect

SAFETY GUIDELINES

the hose for wear, because any of these conditions can damage the hose and possibly result in personal injury.

- Do not use the hose to move attached equipment. Stress can damage the hose and possibly cause personal injury.
- Keep the cylinder clean at all times. While at a job site, when the cylinder is not in use, keep the piston rod fully retracted and upside down.
- Use an approved, high-grade pipe thread sealant to seal all hydraulic connections. PTFE tape can be used if only one layer of tape is used and it is applied carefully (two threads back) to prevent the tape from being pinched by the coupler and broken off inside the pipe end. Any loose pieces of tape could travel through the system and obstruct the flow of fluid or cause jamming of precision-fit parts.
- Always use protective covers on disconnected quick couplers.

ASSEMBLY INSTRUCTIONS

Refer to diagram on page 10.

1. Remove outer components (5, 10, and 13) by twisting nozzle adapter (13) counter clockwise.
2. Insert tie rod (6) through collet adapter (7), lining up the slot in the tie rod with the set screw (8) in the collet adapter.
3. Slide the compression spring (9) over threaded end of the tie rod (6) protruding from the adapter (7).
4. Thread the tie rod (6) into the adapter (12).
5. Insert the threaded end of the draw bar (1) through the front of the collet (2). Will need to tap or drive the threads of draw bar (1) through the collet (2).
6. Thread the collet (2) into the collet adapter (7). Do not thread the draw bar (1) into the collet (2) yet.
7. Replace the outer components (5, 10, and 13) by threading the nozzle adapter (13) back onto the cylinder.
8. Place the nose piece (3) over the nose piece adapter (5).
9. Install the cap screws (4) into the nose piece (3) and through the holes in the nose piece adapter (5).
10. Thread the draw bar (1) into the tie rod (6) just enough that the collet (2) begins to expand during the stroke.
11. Adjust the expansion by threading the draw bar (1) into the tie rod(6) further. Adjust until the collet (2) expands just enough to engage in and remove the tube stub.

NOTE: Over expanding the collet into the tube by way of threading the draw bar too far into the tie rod for the specific tube will result in excess load or pressure to be applied to the neck of the draw bar. This may result in catastrophic failure of the draw bar and as such, create a projectile in the form of the draw bar end. (See safety guidelines for proper use.)

PARTS LISTS & DIAGRAMS



ITEM NO.	QTY	Part Number	Description
1	1	varies by size	Draw Bar
2	1	varies by size	Collet
3	1	varies by size	Nose Piece
4	2	varies by size	Socket Head Cap Screw, #10-24 x 1/4
5	1	CP104	Nose Piece Adapter
6	1	varies by size	Tie Rod
7	1	CP103	Collet Adapter
8	1	P8302-81LP	Socket Head Cap Scev, 1/4-20 x 1/4, Low-Profile
9	1	37-11147	Compression Spring
10	1	CP108	Nozzle
11	1	128BK	Cup Point Set Screw, 1/4-20 x 3/16
12	1	CP106	Adapter
13	1	CP102	Nozzle Adapter
NA	1	CP300	Deflector Shield

START-UP

Unpacking

The Elliott Collet Style Tube Puller is shipped in a carton complete with all accessories listed. A Deflector Shield is also included for use with the Super Collet Tube Puller. This is a 3/8" thick rubber mat, designed to absorb the energy of a projectile in the case of a broken drawbar.

On arrival, check for external damage to the box. If damage is found, notify the carrier and the supplier so insurance inspectors can examine the box before it is unpacked. When opened, check the contents against the packing and parts list. Report any damage or shortage to Elliott.

Ensure that there is no packaging material left inside the openings of the machine, especially in the hydraulic inlets.

Connecting to Hydraulic Power Supply

The Elliott Collet Style Tube Puller requires a hydraulic power source.

1. Place the Collet Style Tube Puller and the hydraulic power source on a flat surface.
2. Select proper tools for puller.
3. Connect the electrical power cord from the pump to a power source.
4. Before operating the pump, all hose connections must be tightened with the proper tools. Do not overtighten. Connections should only be tightened securely and leak-free. Overtightening can cause premature thread failure or high pressure fittings to split at pressures lower than their rated capacities.
5. Connect the hydraulic cylinder power cord of the puller to the power cord on the pump; twist the plugs to lock-in the connection.
6. Connect the two 15' hydraulic hoses to the pump. Important: Make sure that the male hose fitting is totally in contact with female fitting shoulder on the tube pulling cylinder before threading down the locking fitting.
7. Move the pump switch from the off position to the remote position to initiate power to the pump.
8. The Collet Style Tube Puller is now ready for operation.

TOOL CHANGEOVER

Changing the Nosepiece

1. Remove screws (4) in nose piece (3) with Allen wrench and slide nose piece off adapter (5).
2. Insert appropriate nose piece on to nose piece adapter (5).
3. Make sure that the screws engage into holes in the nose piece adapter.
4. Tighten screw to lock in nose piece.

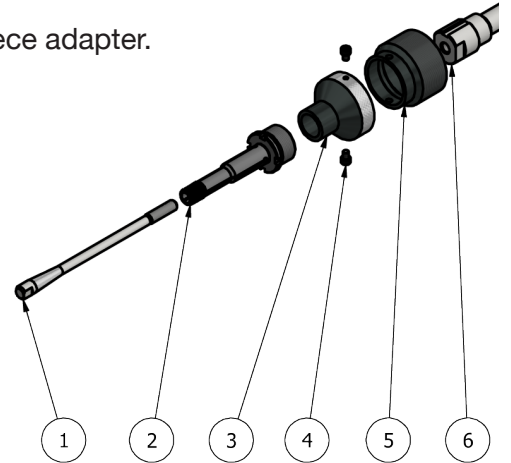

Changing the Draw Bar

1. Rotate the nozzle (10) counter clockwise until it is free from the nozzle adapter (13).
2. Remove the nose piece, nose piece adapter, and nozzle from the assembly.
3. Rotate the draw bar (1) counter clockwise until it is free from the tie rod (6).
4. Rotate the collet (2) counter clockwise until it is free from the collet adapter (7).

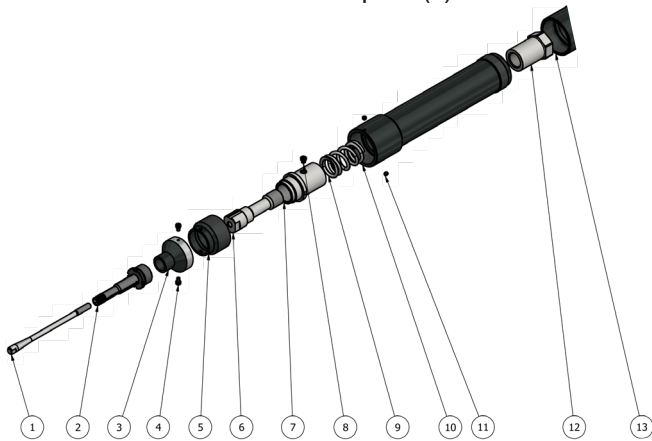

5. Remove draw bar by driving it out through the center of the collet using a punch and hammer, driving from the threaded end of the draw bar.
6. Replace draw bar by inserting the threaded end into the center of the collet and driving it through to the neck of the draw bar.
7. Thread the collet back into the collet adapter and the draw bar back into the tie rod. Thread the collet clockwise into the collet adapter until tight. Thread the draw bar into the tie rod only 2-3 turns, to be adjusted later.

8. Replace the nose piece, nose piece adapter and nozzle by sliding back over the assembly and rotating the nozzle clockwise until tight.
9. To achieve correct setting of draw bar, (do a test pull), after the collet just makes contact with the tube ID, proceed to turn the draw bar 1-2 clockwise revolution.

TOOL CHANGEOVER

Changing the Collet

1. Rotate the nozzle (10) counter clockwise until it is free from the nozzle adapter (13).
2. Remove the nose piece, nose piece adapter, and nozzle from the assembly.
3. Rotate the draw bar (1) counter clockwise until it is free from the tie rod (6).
4. Rotate the collet (2) counter clockwise until it is free from the collet adapter (7).
5. Remove draw bar by driving it out through the center of the collet using a punch and hammer, driving from the threaded end of the draw bar.
6. Replace collet by inserting the threaded end of the draw bar into the center of the new collet and driving it through to the neck of the draw bar.
7. Thread the collet back into the collet adapter and the draw bar back into the tie rod. Thread the collet clockwise into the collet adapter until tight. Thread the draw bar into the tie rod only 2-3 turns, to be adjusted later.
8. Replace the nose piece, nose piece adapter and nozzle by sliding back over the assembly and rotating the nozzle clockwise until tight.
9. To achieve correct setting of draw bar, (do a test pull), after the collet just makes contact with the tube ID, proceed to turn the draw bar 1-2 clockwise revolution.



OPERATION

The Collet Style Stub Puller has been designed for efficient use and optimum productivity. The Collet Style Stub Puller will extract tubes, or tube stubs, with outside diameters ranging from 1/2" (12.7mm) to 2-1/2" (65.3mm). Standard O.D. collets, draw bars, tie rods and nosepieces are available for 1/2" (12.7mm), 5/8" (15.9mm), 3/4" (19.1mm), 7/8" (22.2mm), 1" (25.4mm), 1-1/8" (28.6mm), 1-1/4" (31.8mm), 1-3/8" (34.9mm) and 1-1/2" (38.1mm) O.D. tubes. A kit of tooling components to allow the puller to be used on 2" and 2-1/2" O.D. tubes is also available.

Four standard collet sizes are available.

1. Determine the O.D. and I.D. of the tubes to be extracted.
2. Select and install proper tools: Nose piece, tie rod, draw bar, and collet. (See chart on page 9 and 10.)
3. Secure Collet Style Stub Puller to counter balance, for either horizontal or vertical operation.
4. Start the initial collet adjustment by unscrewing the draw bar so that there is approximately 3/4" of the straight portion of the bar appearing between the base of the draw bar cone and the front of the collets. Initial adjustment of the nosepiece will position the front of the nosepiece approximately 3/16" behind the back collet tooth.
5. Attach the Deflector Shield to the back end of the tube sheet as appropriate. This will absorb the energy of a projectile in the case of a broken drawbar.
6. Insert the collet into one of the tubes to be pulled and press the retract button to cycle the puller. The first pull will probably not engage the tube. Tighten the draw bar 1 to 2 turns and repeat the operation. Repeat this sequence until the collets finally grab the inside of the tube. The collet will probably slide, or "broach", the tube I.D. on the last pull. Tighten the draw bar 1.5-2 turns for a final adjustment. You are now ready to pull tubes. (Note: This adjustment sequence may seem awkward, but it allows the puller to operate at a minimum of pressure while efficiently pulling tubes. If an oversized tube is encountered, the draw bar can be temporarily tightened and then returned to the original setting.)
7. If needed, the handles can be adjusted in 90° increments to fit working conditions. To adjust, loosen handle hex bolt and adjust handle and retighten hex bolt.
8. Insert the collet into tube until nosepiece is positioned against the tube sheet.
9. To pull tube:
 - a.) Tap retract button to straighten collet unit inside of tube and to align puller with tube sheet. Now the collet has proper contact with the tube I.D.
 - b.) Press and hold retract button to initiate full stroke of the puller and continue to extract the tube. The tube should now be extracted 6".
 - c.) If it is necessary to extract further, re-engage draw bar into tube and repeat (1) and (2). This should have extracted the tube approximately one additional inch.
10. Once the tube joint has passed through the tube sheet, remove the puller by pressing the extend button until the collet and draw bar are fully protruded, and pull the tube by hand until the tube is completely extracted from the vessel.

TROUBLESHOOTING

Symptom	Solution
Failure to pull tubes in a serrated, or grooved, tube sheet.	Ensure that the collets are not engaging on the serration. Proper engagement location is just before the first serration.
Button action is opposite desired (would prefer retract button to advance the cylinder, vice versa)	Switch the hydraulic hose connections at the pump.
Tool Breakage/Failure	(See Below)

Main Causes of Breakage

1. Misalignment of the puller with the tube sheet. It is important to keep the unit straight. If tube projection is not a problem, the unit can be operated without the nosepiece, using only the nosepiece adapter. This allows a more stable base to pull from.
2. Excessive pressure on the draw bar / collet / tube interface caused by over-tightening the draw bar. You will see higher pressure reading on the pump when this happens.
3. The puller is designed to withstand the full force of the hydraulic cylinder. However, it is important that all components remain fully threaded (with the exception of the draw bar) during operation to maintain this integrity. Before operating, ensure all threaded connections are tight and secure.

Problem	Cause	Solution
Cylinders will not extend or retract but pump achieves full pressure.	Hose connector not properly seated or pressurized.	Disconnect hoses, relieve pressure in hoses by depressing ball into a rag on floor. To relieve pressure in female connector insert wooden dowel into fitting, wrap a rag around connector and tap with a hammer.

WARRANTY

Should any part, of Seller's own manufacture, prove to have been defective in material or workmanship when shipped (as determined by Seller), Seller warrants that it will, at its sole option, repair or replace said part f.o.b., point of manufacture, provided that Buyer notifies, in writing, of such defect within twelve (12) months from date of shipment from the manufacturing plant.

On request of Seller, the part claimed to be defective will be returned, transportation, insurance, taxes and duties prepaid, to the factory where made, for inspection. Any item, which has been purchased by Seller, is warranted only to the extent of the original manufacturer's warranty to Seller. Seller shall not be liable for any damages or delays caused by defective material or workmanship.

No allowance will be made for repairs or alterations made by others without Seller's written consent or approval. If repairs or alterations are attempted without Seller's consent, Seller's warranty is void.

THE WARRANTIES PROVIDED IN THE OBLIGATIONS AND LIABILITIES OF SELLER HEREUNDER, AND THE RIGHTS AND REMEDIES OF BUYER HEREUNDER ARE EXCLUSIVE AND IN SUBSTITUTION FOR, AND BUYER HEREBY WAIVES ALL OTHER WARRANTIES, GUARANTEES, OBLIGATIONS, CLAIMS FOR LIABILITIES, RIGHTS AND REMEDIES, EXPRESS OR IMPLIED, ARISING BY LAW OR OTHERWISE, INCLUDING BUT NOT LIMITED TO THE IMPLIED WARRANTY FOR MERCHANTABILITY AND FITNESS FOR PURPOSE.

Seller's total liability is limited to the lower of the cost of repair or replacement.



Contact Us

Elliott Tool offers a complete line of precision tube tools to meet your needs. Contact us or your local support.

Elliott Tool Technologies, Ltd.
1760 Tuttle Avenue
Dayton, Ohio 45403-3428
Phone: +1 937 253 6133 • +1 800 332 0447
Fax: +1 937 253 9189
www.elliott-tool.com

Printed in the USA
©07/2021 Elliott Tool Technologies, Ltd.
TM-127
PL-112

Locally Supported By:

www.elliott-tool.com/support